

SPECIFICATIONS	
CONTACT CARRIER MATERIAL	NYLON OR TPU
CONTACT MATERIAL/PLATING	BRASS/GOLD
HOUSING/LOCKNUT MATERIAL	BRASS/NICKEL
RATED CURRENT [A]	4.0 A
RATED VOLTAGE [V]	250 V
NUMBER OF CONDUCTORS [AWG]	5x22 AWG
TEMPERATURE RATING	-30°C to +80°C (-22°F to +176°F)
PROTECTION CLASS	MEETS NEMA 1,3,4,6P AND IEC IP68
MAX. PANEL THICKNESS	3.0 [0.12]

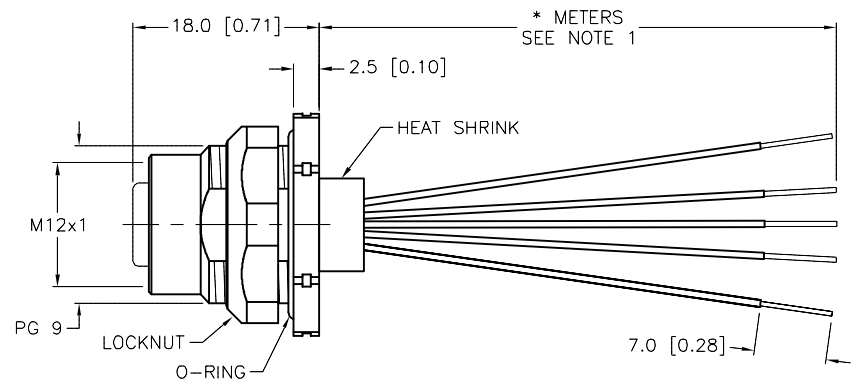
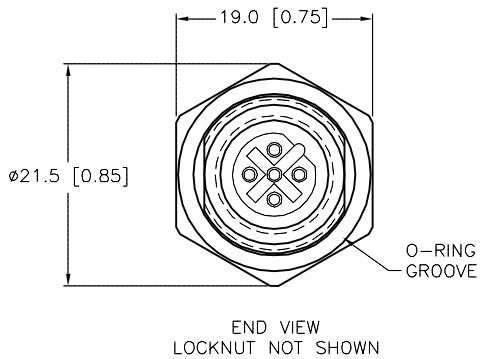

CABLE LENGTH	TOLERANCE*
ALL LENGTHS	+ 4% (OR 50mm) OF LENGTH - 0% (OR 0mm) OF LENGTH WHICHEVER IS GREATER
STRIP LENGTH	TOLERANCE*
0-7mm	±0.5mm
8-29mm	±1.0mm
30-49mm	±2.0mm
50-69mm	±3.0mm
70-100mm	±4.0mm
OVER 100mm	±5.0mm

\* UNLESS OTHERWISE SPECIFIED

NOTES:  
1. "\*" INDICATES LEAD LENGTH IN METERS. CONTACT TURCK TO ORDER SPECIFIC LENGTHS.

SOURCE DRAWING - FOR REFERENCE ONLY

RELATED DOCUMENTS 1. 2. 3. 4.	3RD ANGLE PROJECTION 	THIS DRAWING IS CONFIDENTIAL AND THE PROPERTY OF TURCK INC. USE OF THIS DOCUMENT WITHOUT WRITTEN PERMISSION IS PROHIBITED.		3000 CAMPUS DRIVE MINNEAPOLIS, MN 55441 1-800-544-7769 (763) 553-7300 (763) 553-0708 fax turck.com		
		DRFT	JB	DATE	05/09/01	DESCRIPTION FKFDW 4.5-*
MATERIAL SEE SPECIFICATIONS	ALL DIMENSIONS DISPLAYED ON THIS DRAWING ARE FOR REFERENCE ONLY	APVD		SCALE	1=.8	
FINISH SEE SPECIFICATIONS		CONTACT TURCK FOR MORE INFORMATION	UNIT OF MEASUREMENT <b>MILLIMETER [ INCH ]</b>		IDENTIFICATION NO.	REV E
E DRAWING PROCESSED AS PART OF ECO 27885		KMY	01/06/12	27885	DO NOT SCALE THIS DRAWING	
REV	DESCRIPTION	BY	DATE	ECO NO.	FILE: 777000234	SHEET 1 OF 1